

Assembly Guide

CW-116

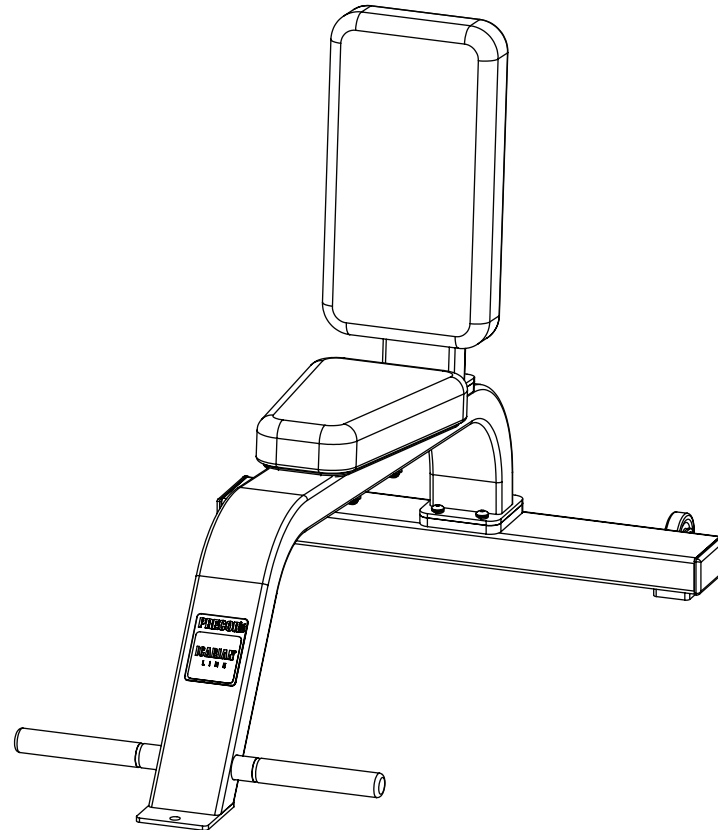

PRECOR USA 

Important Safety Instructions

Before beginning any fitness program, you should obtain a complete physical examination from your physician.

French equivalent of the preceding paragraph, for the Canadian market: Il est conseillé de subir un examen médical complet avant d'entreprendre tout programme d'exercice. Si vous avez des étourdissements ou des faiblesses, arrêtez les exercices immédiatement.

When using exercise equipment, basic precautions should always be taken, including the following:

- Read all instructions before assembling the CW-116. These instructions are written for your safety and to protect the unit.
- Do not allow children or those unfamiliar with its operation on or near the equipment. Do not leave children unsupervised around the unit.
- Read each step in the assembly instructions and follow the steps in sequence. Do not skip ahead. If you skip ahead, you may learn later that you have to disassemble components and that you may have damaged the equipment, which would void the Precor Limited Warranty.
- Use the equipment only for its intended purpose. Do not use accessory attachments that are not recommended by the manufacturer, as such attachments may cause injuries.
- Wear proper exercise clothing and shoes for your workout and avoid loose clothing. Do not wear shoes with heels or leather soles. Tie long hair back.
- **Do not overexert yourself or work to exhaustion.** Use reasonable judgement when working with weights. Avoid using excessive weight, which may cause injury.
- If you feel pain, faintness, dizziness, or abnormal symptoms, stop exercising immediately and consult your physician.
- Assemble and operate the CW-101 on a solid, level surface. Locate the unit a few feet from walls or furniture to provide easy access.
- Do not use outdoors.
- Do not attempt to service the CW-116 yourself. The unit does not contain any user-serviceable parts.

Obtaining Service

For information about product operation or service, refer to the Precor web site at www.precor.com where you can also find customer support numbers or a list of Precor authorized service centers.

If you contact Customer Support, have the serial number available.

You can find the serial number printed on a label affixed to the CW-116. For future reference, write the serial number in the space provided below.

Serial number:

IMPORTANT SAFETY INSTRUCTIONS

Table of Contents

	Important Safety Instructions.....	3
	Obtaining Service	3
1	Preparations.....	5
	Unpacking the Equipment	5
	Required Tools.....	5
	Installation Requirements.....	5
	Hardware Kit.....	6
2	Assembly Instructions	7
	Open the Box.....	7
	Assemble the Unit	8
	Assemble the Pads.....	9
	Clean the Pads and Assembly.....	9
	Product Specifications.....	12

1

Preparations

The CW-116 parts are inspected before shipment. Each unit contains several pieces that require assembly. You may find it helpful to ask for assistance during the assembly process.

Unpacking the Equipment

When you open a box, carefully unpack the pieces and lay them on the floor near the location where you plan to use them.

CAUTION: Be careful when you remove the packaging material with a utility knife. Do not cut the upholstery or scratch the paint.

If any items are missing, contact the dealer from whom you purchased the unit. For more information, refer to *Obtaining Service*.

Required Tools

Tools that you need to obtain before assembling the unit include:



- ❑ Wire cutter or utility knife

Installation Requirements

Follow these installation requirements when assembling the unit:

- **Review the *Important Safety Instructions*.**
- **Assemble the unit where it will be used.**
Provide ample space around the unit.
- **Install components in the sequence shown.**
- **Insert all fasteners in the same direction.**
For aesthetic purposes, insert all the fasteners in the same direction unless specified (in text or illustrations) to do otherwise.
- **Leave room for adjustments.** Tighten the fasteners to keep the unit stable, but leave room for adjustments. Do not fully tighten fasteners until instructed to do so.

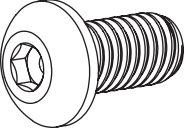
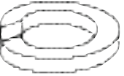
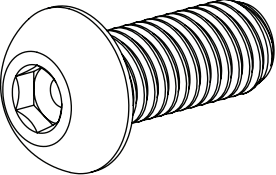
Hardware Kit

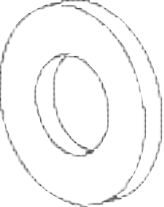
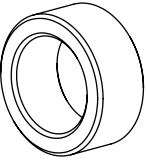
Fastener	Qty
 <p data-bbox="423 373 824 403">3/8 x 3/4-inch Buttonhead screw (A)</p>	8
 <p data-bbox="423 501 707 531">3/8-inch Split washer (B)</p>	8
 <p data-bbox="423 663 842 694">1/2 x 1 1/4-inch Buttonhead screw (C)</p>	1
 <p data-bbox="423 807 707 837">1/2-inch Split washer (D)</p>	1
 <p data-bbox="423 967 651 997">1/2-inch Washer (E)</p>	1
 <p data-bbox="423 1190 555 1220">Spacer (F)</p>	1

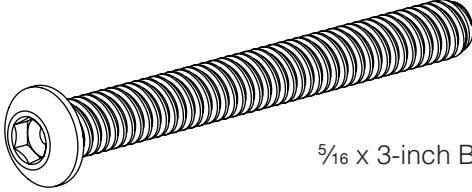
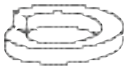
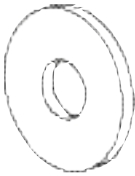
Fastener	Qty
 <p data-bbox="1473 459 1877 489">5/16 x 3-inch Buttonhead screw (G)</p>	8
 <p data-bbox="1473 547 1765 577">5/16-inch Split washer (H)</p>	8
 <p data-bbox="1473 695 1704 726">5/16-inch Washer (J)</p>	8

2

Assembly Instructions

Assembly of the CW-116 takes about 20 minutes to complete. If this is the first time you have assembled this type of equipment, plan on allowing more time.

Be careful to open boxes and assemble components in the sequence presented in this manual.

Note: With so many assembled parts, proper alignment and adjustment is critical. While tightening the fasteners, be sure to leave room for adjustments.

Do not fully tighten fasteners until instructed to do so.

Open the Box

Use wire cutters to open the box and remove the packing materials.

The illustration shows how the CW-116 will look when you have completed its assembly. The callouts identify specific pieces.

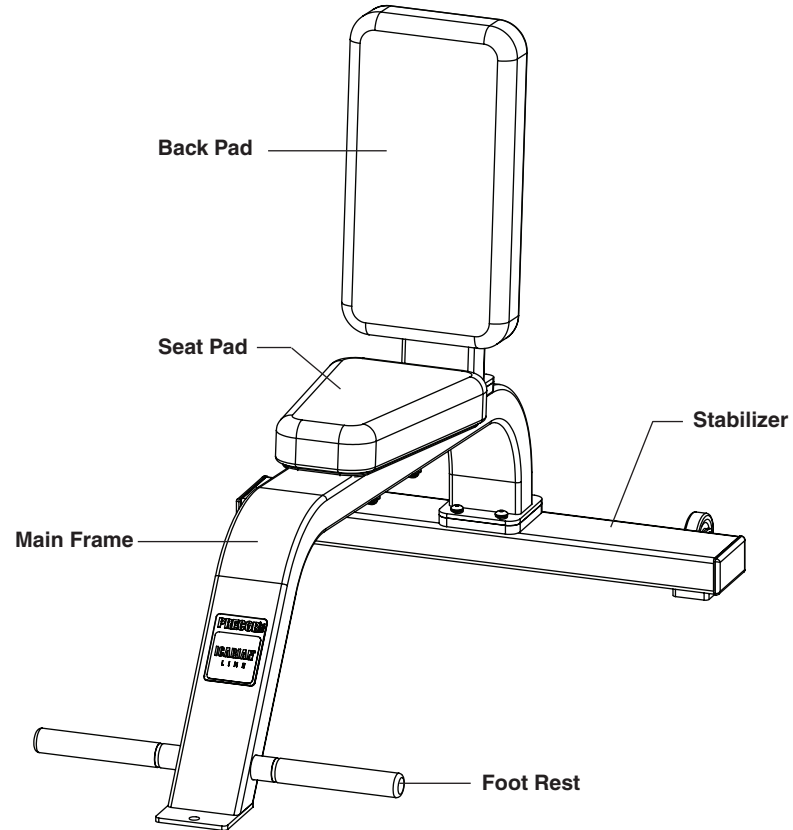

Assemble the Unit

1. Attach the Main Frame to the Stabilizer using
four $\frac{3}{4}$ -inch buttonhead screws (A)
four $\frac{3}{8}$ -inch split washers (B)
Wrench tighten.

Note: Make sure the wheels on the Stabilizer are positioned as shown in the illustration.

2. Attach the Back Support to the Main Frame using
four $\frac{3}{4}$ -inch buttonhead screws (A)
four $\frac{3}{8}$ -inch split washers (B)
Wrench tighten.

3. Slide the Foot Rest through the Main Frame and secure it using
one $1\frac{1}{4}$ -inch buttonhead screw (C)
one $\frac{1}{2}$ -inch split washer (D)
one $\frac{1}{2}$ -inch washer (E)
one spacer (F)
Wrench tighten.

Note: For ease of assembly, place a split washer, a flat washer, and a spacer onto each screw before inserting the screw.

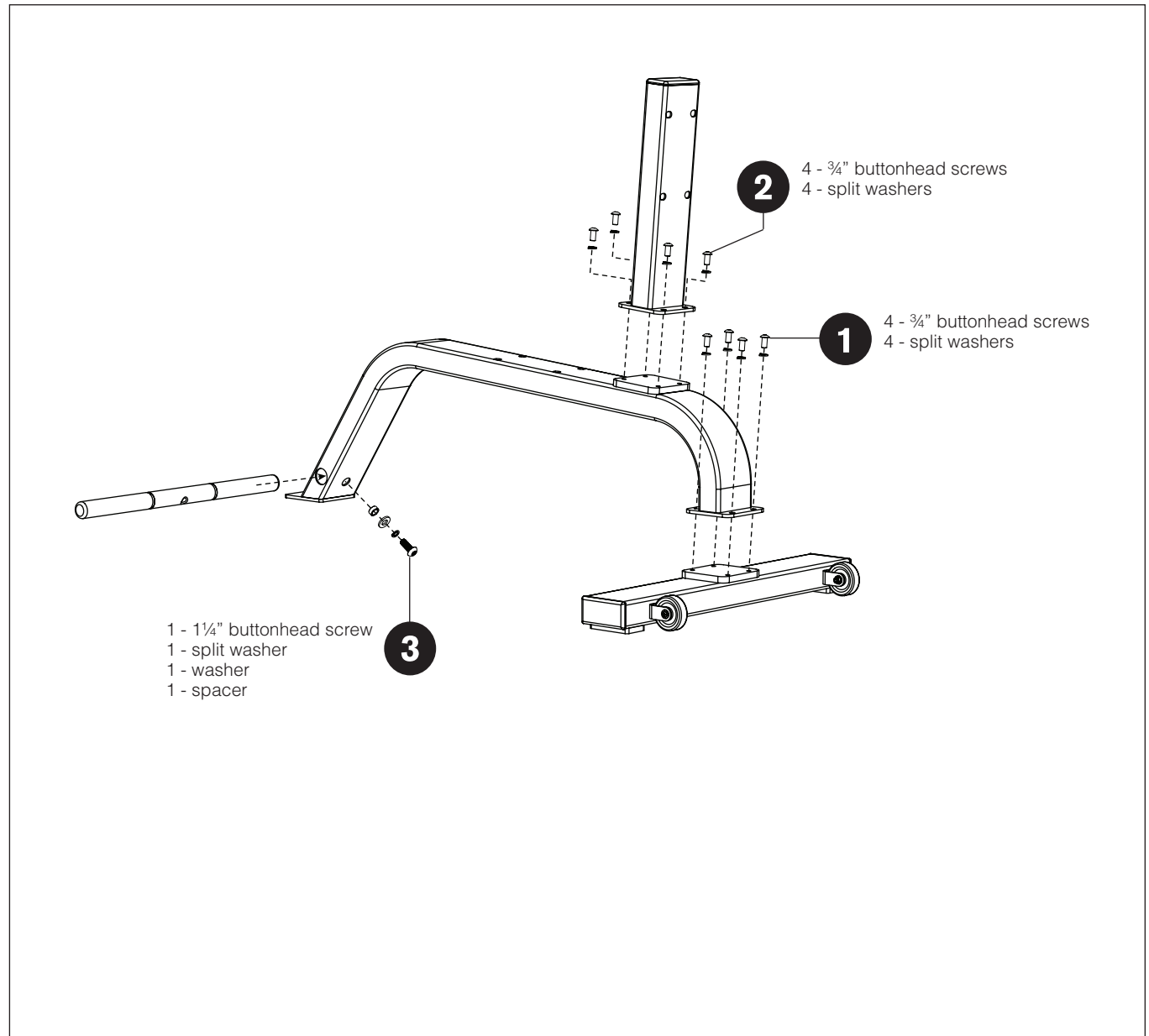

Assemble the Pads

1. Attach the Back Pad to the Back Support using
four 3-inch buttonhead screws (G)
four $\frac{5}{16}$ -inch split washers (H)
four $\frac{5}{16}$ -inch washers (J)
Wrench tighten.
2. Attach the Seat Pad to the Main Frame using
four 3-inch buttonhead screws (G)
four $\frac{5}{16}$ -inch split washers (H)
four $\frac{5}{16}$ -inch washers (J)
Wrench tighten.

This completes the assembly of the CW-116.

Clean the Pads and Assembly

To clean the pads, moisten a clean, soft cloth in a mild solution of soap and water and wipe all the parts thoroughly. Dry the pads with a clean, dry cloth.

Use the same procedure to clean the main structure.

Frequently vacuum the floor underneath the CW-116 to prevent the accumulation of dust and dirt. If necessary, use the Foot Rest to lift the front end and tip the CW-116 onto its wheels to roll it to a different location.

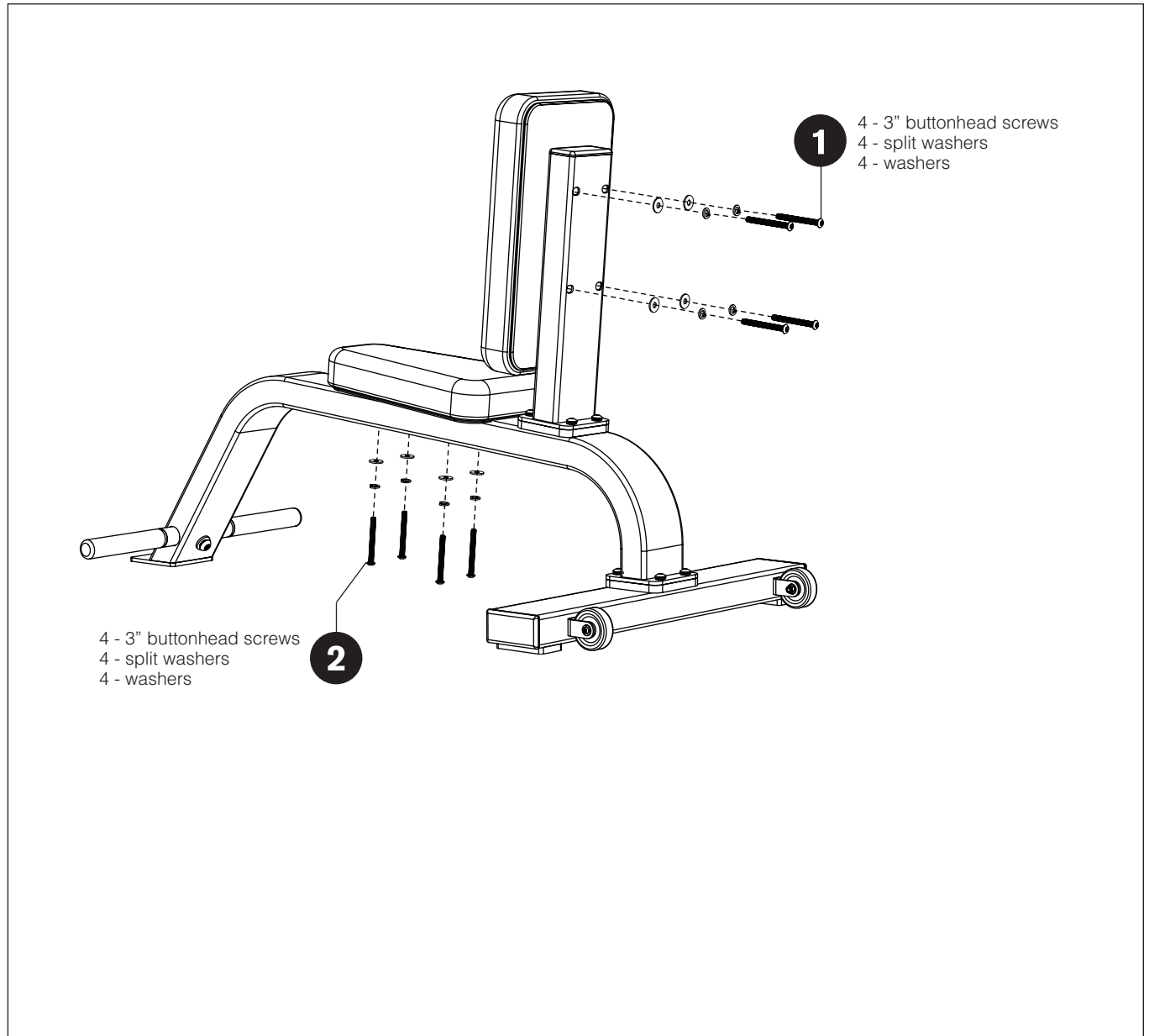

Assemble the Pads

Notes:

Notes:

CW-116 Specifications

Length: 46 inches (117 cm)

Height: 33 inches (82 cm)

Width: 30 inches (76 cm)

Shipping weight: 65 lb (30.48 kg)



Precor Incorporated
20031 142nd Avenue NE
P.O. Box 7202
Woodinville, WA USA 98072-4002
1-800-347-4404

Precor, Icarian, and Move Beyond are registered trademarks of Precor Incorporated.

Copyright 2014 Precor Incorporated.

Specifications subject to change without notice.

www.precor.com

NOTICE:

Precor is widely recognized for its innovative, award winning designs of exercise equipment. Precor aggressively seeks U.S. and foreign patents for both the mechanical construction and the visual aspects of its product design. Any party contemplating the use of Precor's product designs is hereby forewarned that Precor considers the unauthorized appropriation of its proprietary rights to be a very serious matter. Precor will vigorously pursue all unauthorized appropriation of its proprietary rights.

General Safety & Maintenance Manual

Precor Icarian Line
Commercial Strength Equipment



Important Safety Guidelines for Owners

Follow these guidelines to maintain proper working condition of the equipment:

Important: *Do not modify the equipment or any of its parts, or permanently remove any part from the equipment. Do not use accessory attachments that are not recommended by Precor, as such attachments might cause injuries.*

- Qualified technicians must perform all regular maintenance.
- Check that all fasteners are securely tightened. Cables should be secured at both end connections and properly threaded. Weight stacks should be secure and functioning properly. Handle attachments should be properly connected.
- Make sure that trainers, facility personnel, and maintenance technicians understand how to use the equipment, know important safety guidelines, and can recognize potential problems such as a worn cable, loose hardware, or cracked weld.
- Strength training requires a significant focus by the facility and its staff to maintain the quality of the fitness environment. If possible, the facility should provide direct supervision of the fitness equipment at all times by people knowledgeable about the safe operation of the equipment and trained to recognize potential problems.

- If any staff member witnesses unsafe use of the equipment, he or she should address the user directly, demonstrate the proper technique, and review the *Important Safety Information for Users*. *Precor recommends posting a copy of the Important Safety Information for Users near the equipment in a prominent location.*
- Make sure the equipment is stable and placed on a solid, level surface. The equipment is designed to be freestanding; however, it can be bolted to the floor for extra stability. Precor highly recommends that the equipment be bolted to the floor to reduce the risk of toppling the equipment due to improper use. Since floor construction varies, please consult a professional building engineer for proper fastening.
- Locate the equipment at least 40 inches (1 meter) away from walls or furniture on either side of the equipment, and 40 inches (1 meter) away from objects behind the equipment. For Functional Training equipment, make sure that the operating space is large enough to allow the cables to be fully extended in all possible directions.
- Check the equipment thoroughly based on the recommended inspection schedules outlined in this manual, including daily, weekly, monthly and annual checks. Ensure all bolt connections are tight and that the threaded cables are properly and tightly secured at both ends.
- Place an “out-of-order” sign on the equipment during maintenance of the equipment or the surrounding area. Users should never be allowed to operate the equipment until it has been inspected and works properly. If a piece of equipment needs service, keep it out of use until it is repaired.

- When working with the weight stacks, do not attempt to free any jammed assemblies without assistance as this may cause injury. With the help of another person, carefully return the weight stack to the proper position with the top plate resting on the first weight.
- Do not allow the equipment to be used if the top plate or weight stack is pinned in a raised position. With the help of another person, carefully return the machine to the proper position with the top plate resting on the first weight. Inspect the cable to ensure that it is seated in all of the pulleys.

- Whenever a weight can drop and hit a user, such as with an Olympic bench, Precor highly recommends that a helper or spotter be used to ensure a safe workout with the equipment.
- Do not place the equipment outdoors or on wet surfaces.

Safety Approval

Certain Precor commercial strength equipment is Class S/C certified according to EN957 –1/2 standards. See an authorized Precor dealer for a complete and current listing of certified machines.

Important Safety Information for Users

Before beginning any fitness program, you should obtain a complete physical examination from your physician.

French equivalent of the preceding paragraph, for the Canadian market: Il est conseillé de subir un examen médical complet avant d'entreprendre tout programme d'exercice. Si vous avez des étourdissements ou des faiblesses, arrêtez les exercices immédiatement.

When using exercise equipment, you should always take basic precautions, including the following:

- If you do not understand how to operate a piece of equipment, ask someone from the facility such as a trainer to demonstrate how to use it and explain any safety instructions.
- Do not allow children on or near the equipment. Do not leave children unsupervised around the equipment.
- Use the equipment only for its intended purpose. Do not use accessory attachments that are not recommended by the manufacturer, as such attachments may cause injuries.
- Wear proper exercise clothing and shoes for your workout—no loose clothing.
- **Do not overexert yourself or work to exhaustion.** Use reasonable judgment when working with weights. Avoid using excessive weight, which may cause injury.
- If you feel pain, faintness, dizziness, or abnormal symptoms, stop exercising immediately and consult your physician.
- Keep head, limbs, fingers, and hair clear of all moving parts while the equipment is in use. Keep hands clear of racking pegs.

- Never drop or insert objects into any opening in the equipment.
- Check that all fasteners are securely tightened. Cables should be secured at both end connections and properly threaded. Weight stacks should be secure and functioning properly. Handle attachments should be properly connected. Pay particular attention to the condition of cables and cable ends. If you notice a loose cable end or any fraying of the cable or cable jacket, do not use the product and contact someone in the facility immediately.
- Always check the equipment before using it. If you spot a potential problem, contact someone in the facility immediately. Do not use the equipment until the facility has verified that the equipment is working properly. Do not attempt to fix broken or jammed equipment.
- Do not use the equipment outdoors.
- Do not drop or slam the weight stack while exercising.
- Be sure the selector pin is completely inserted. Use only the pin provided by the manufacturer. If unsure, contact someone in the facility.
- Never pin the weights in an elevated position. Do not use the equipment if the top plate or weight stack is pinned in a raised position. Notify facility's personnel to repair the equipment and ensure that it is working properly.
- Do not use the equipment if an "out of order" sign has been placed on it.
- Read all posted instructions, including all safety instructions and warnings.

Table of Contents

Important Safety Guidelines for Owners	1	Weekly Inspection	15
Safety Approval	3	Condition and Deep Clean Upholstery	15
Important Safety Information for Users	4	Clean and Lubricate Cable Rod Ends	16
Before You Begin	7	Clean and Lubricate Guide Rods	16
Recommended Tools	7	Inspect Cables, Connections, and Tension	17
Obtaining Service	8	Inspect Cable Handle Attachments	18
Daily Inspection	9	Inspect Pulleys	18
Clean Upholstery	9	Inspect Weight Stack and Selector Pin	18
Inspect Pads for Wear	10	Inspect and Lubricate Bearings and Bushings	19
Clean and Inspect Frames	10	Check Seat Adjustment and Test Pop Pins	20
Inspect All Fasteners	11		
Inspect Cables and End Connections	11		
Check Warning Labels and Instruction Placards	13		

Monthly Inspection	21
Inspect Frames and Movement Arms	21
Lubricate Pop Pins	22
Check and Lubricate Ratcheting Seat Lever	23
Inspect All Fasteners	24
Annual Maintenance	25
Weight Stack Annual Maintenance	25
Inspect and Lubricate Pop Pins	26
Recommended Maintenance Checklist	27

Before You Begin

Precor recommends implementing a thorough maintenance program that incorporates regular safety inspections by qualified maintenance technicians as outlined in this manual.

This manual explains how to maintain the Precor Icarian line of commercial strength equipment. It provides information about items that need to be inspected and maintained on a daily, weekly, monthly, and annual basis. You should perform those tasks that are appropriate for the equipment you are maintaining, and skip those tasks that do not apply. To help you, a checklist is located at the back of this manual that you can follow during your maintenance checks to ensure that nothing appropriate is missed and that your inspection process is documented.

This manual covers the general maintenance procedures that you can perform in the fitness facility. However, if the equipment requires service beyond the maintenance procedures covered in this manual, refer to *Obtaining Service*.

Important: *Always purchase replacement parts and hardware from Precor. These parts are tested and manufactured specifically for the Precor Icarian line of commercial strength equipment. If you use parts not approved by the manufacturer, you could void the Precor Limited Warranty. Use of parts not approved by Precor may cause injury.*

Precor recommends that maintenance technicians thoroughly read and understand the safety guidelines and maintenance procedures covered in this manual.

Note: If the equipment requires assembly, a separate assembly guide is provided. For information on how to use a piece of equipment, refer to the instructional label found on the equipment.

Recommended Tools

We recommend that you put together a toolbox with the following tools. This list covers the tools you may need when you inspect and maintain the equipment.

- Complete combination box wrench set from $15/16$ to $1/2$ -inch
- Complete socket set from $15/16$ to $1/2$ -inch
- Hex nut driver: $1/4$ -inch
- 12-inch adjustable wrench
- Complete hex key set from $3/8$ to $5/64$ -inch
- Rubber mallet
- Straight shank punch: $1/4$ -inch

Obtaining Service

You should not attempt to service the strength equipment, except for the maintenance tasks described in this manual. If any items are missing, contact your dealer. If you need more information regarding customer support numbers or a list of Precor authorized service centers, visit the Precor website at www.precor.com.

If you have any questions regarding a piece of equipment, locate its serial number and contact Precor Customer support. Precor uses the serial number to establish the model and year of the product. You can generally find the serial number underneath the seat support.

For future reference, write the serial numbers, model numbers, and dates of purchase for your Precor strength training equipment in the space provided. You may want to list all equipment information below for easy reference.

Model #: _____ Serial #: _____

Date purchased: _____

Model #: _____ Serial #: _____

Date purchased: _____

Model #: _____ Serial #: _____

Date purchased: _____

Model #: _____ Serial #: _____

Date purchased: _____

Model #: _____ Serial #: _____

Date purchased: _____

Model #: _____ Serial #: _____

Date purchased: _____

Model #: _____ Serial #: _____

Date purchased: _____

Model #: _____ Serial #: _____

Date purchased: _____

Model #: _____ Serial #: _____

Date purchased: _____

Daily Inspection

You will need to perform the following tasks each day to maintain the equipment and keep it operating smoothly:

- Clean any upholstery on the equipment.
- Inspect pads for wear.
- Clean and inspect equipment frames.
- Inspect cables and end connections for wear.
- Check warning and instructional labels for readability.
- Check that all fasteners are properly secured.

Clean Upholstery

To remove surface dirt and perspiration, clean upholstery daily with a mild soap and water solution in a spray bottle. Spray upholstered surfaces lightly and wipe dry with a clean cloth.

Important: To clean the upholstery, do not use cleaning products that have any of these ingredients: solvents, alcohol, ammonia, or petroleum. Use a mild detergent-based cleaner instead.

Inspect Pads for Wear

Inspect pads for cracks in the upholstery, broken and loose stitching, loose staples, and loose mounting bolts. Replace pads as needed (refer to *Obtaining Service* to purchase new pads.)

Important: Do not reupholster pads or use pads not approved by Precor.

Clean and Inspect Frames

To remove grease and dirt, clean frames daily with a mild soap and water solution in a spray bottle. Wipe the equipment down with a damp cloth and dry completely. Be sure to wipe down both painted parts and chrome or plated parts.

To restore and maintain luster of chrome parts, use a commercial chrome cleaner.

As you clean, inspect the frames for cracks, rust, or other damage. Make sure welds are solid and fasteners are properly secured.

Inspect All Fasteners

Fasteners can loosen with normal use. Inspect all nuts, bolts, screws and other fasteners to make sure they are tight and installed correctly.

Be sure to check fasteners at bolted joints to make sure the connections are secure. If a fastener is loose but in good condition, retighten it. If you are concerned about the integrity of the fastener, remove it, clean the threads and inspect it for any damage such as cracks, bad threads, corrosion, or rust. Reinstall the fastener if it appears to be in good condition. Otherwise, remove the equipment from service until a new fastener can be installed properly. You can order new fasteners from Customer Support. For additional information refer to *Obtaining Service*.

Important: *Fastener quality and specifications vary considerably. Replace only with the Precor approved fastener specifically engineered for the precise application. Failure to do so will void the Precor Limited Warranty.*

Inspect Cables and End Connections

CAUTION: Carefully inspect the cables, pulleys, fasteners, and related hardware regularly. Replace any cable at the first sign of wear using only Precor-supplied replacement parts. With regular use, a cable can become worn and might fail. Sudden failure of a worn cable can cause severe injury to a user. Refer to ***Obtaining Service*** to purchase replacement parts.

Inspect the cables and end connections each day, and replace if damaged. Check for kinks, frayed wires, or deterioration of the cable coating. Look for signs of wear particularly at crimped ends of the cable and near pulleys. (Refer to Figure 1.)

Important: *Cables must be replaced immediately if they are damaged to avoid possible injury to users.*

Some obvious signs of cable damage are as follows:

1. Exposed inner wire, stretching or cuts in the coating, or broken coating in the area that passes over a pulley
2. A zigzag or wavy pattern
3. Kinks, which may indicate internal damage
4. A necked-down cover
5. A 'ballooned' cover

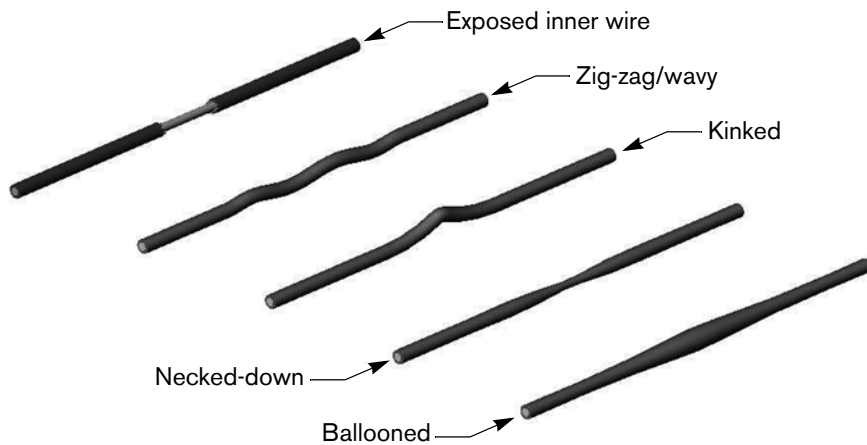

Figure 1: Signs of cable damage

In addition to inspecting the cables and end connections for damage, check the following:

- Ensure that each cable is properly adjusted and tightened at the top of the weight stack.
- Check cable pulleys, end connections, and end fittings. Make sure all connections are tight, adjusting cable tension as necessary.
- Make sure that the cable bolt is threaded at least seven turns into the selector stem or a minimum of ½-inch (13 mm). The distance shown should be ¾-inch (19 mm) or less. Tighten the locking jam nut to 600 in-lb (68 N-m). Refer to Figure 2.

Cable bolt must be inserted a minimum of 7 threads into the selector stem.

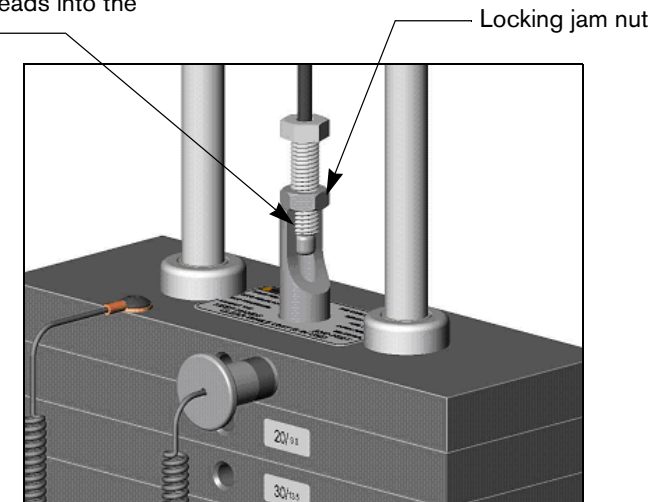

Figure 2: Proper cable bolt insertion

Check Warning Labels and Instruction Placards

Inspect warning and instructional labels daily to make sure that all the information can be clearly read. If any portion is not visible or part of the label is not adhered properly, replace that label immediately (refer to *Obtaining Service* for purchase information).

Clean labels and placards as needed with a mild soap and water solution in a spray bottle, and dry thoroughly with a soft cloth.

The following figure shows an example of a user instructional label.

Figure 3 shows a typical user instruction placard.

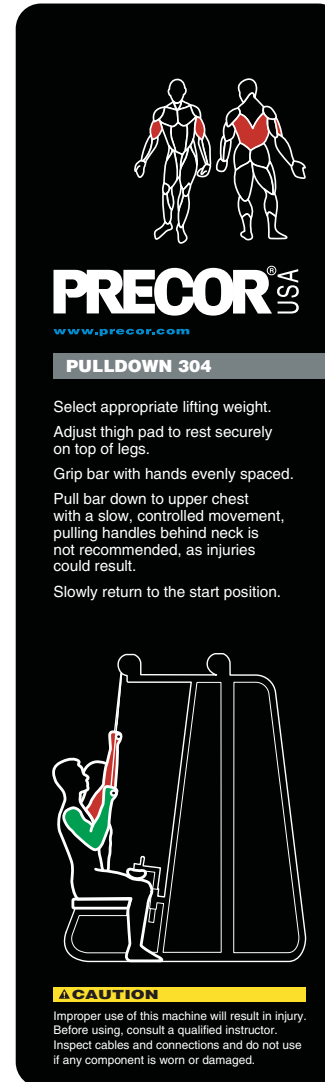

Figure 3: Sample user instruction placard

Precor products come equipped with a number of standard warning labels. The following figures show sample warning labels you may see on the equipment depending on the model and product line:

KEEP HANDS AND FEET CLEAR WHILE MACHINE IS IN USE

Figure 4: This warning label may appear on weight stacks with a pulley mounted at the top

The weight stack cable bolt must be inserted a minimum of seven full turns into the selector stem, and the jam nut tightened down firmly against the selector stem top.

KEEP HANDS AND FEET CLEAR WHILE UNIT IS IN USE!

⚠ WARNING

Figure 5: This warning label may appear on or near weight stacks where a cable bolt is threaded into the selector stem

⚠ WARNING

**SERIOUS INJURY
COULD OCCUR IF
THESE PRECAUTIONS
ARE NOT OBSERVED**

Read all warnings and obtain proper instruction on use of the machine prior to using.

Obtain a medical exam prior to beginning an exercise program.

Keep head, limbs, fingers, and hair clear of all moving parts.

Inspect machine prior to use. Do NOT use if it appears damaged or inoperable.

Do NOT attempt to fix a broken or jammed machine. Notify floor staff.

Use the machine only for the intended use. Obtain instruction and DO NOT modify the machine.

Be certain that weight pin is completely inserted. Use only the pin provided by the manufacturer. If unsure, seek assistance.

Never pin the weights in an elevated position. DO NOT use the machine if found in this condition. Seek assistance from floor staff.

Children must not be allowed near this machine.

Teenagers must be supervised in the use of this machine.

DO NOT REMOVE THIS LABEL.
REPLACE IF DAMAGED.

Figure 6: A version of this warning label appears on the equipment frame

Weekly Inspection

This section covers the tasks you should do each week to maintain the equipment. Perform the following tasks as appropriate for the unit you are maintaining:

- Condition and deep clean upholstery.
- Clean and lubricate cable rod ends.
- Clean and lubricate guide rods.
- Inspect cables, connections, and tension.
- Inspect cable handle attachments.
- Inspect pulleys.
- Inspect each weight stack and selector pin.
- Inspect and lubricate bearings and bushings.
- Check seat adjustment and test pop pins.

Condition and Deep Clean Upholstery

Condition and deep clean the upholstery weekly with a lanolin-based hand cleaner or upholstery cleaner.

Important: To clean the upholstery, do not use cleaning products that have any of these ingredients: solvents, alcohol, ammonia, or petroleum. Use a mild detergent-based cleaner instead.

Clean and Lubricate Cable Rod Ends

Inspect the exposed areas of the guide rods for cleanliness. Using a dry cloth, wipe any buildup of dirt or grease from the rods. Check cable rod ends to ensure the shoulder bolt is secure. If cable rod ends are noisy, you can lubricate them with a silicone spray lubricant, such as Super Lube®. Spray the lubricant onto the joint where the spherical portion is enclosed in the outer housing (refer to Figure 7). Wipe off any excess lubricant with a cloth.

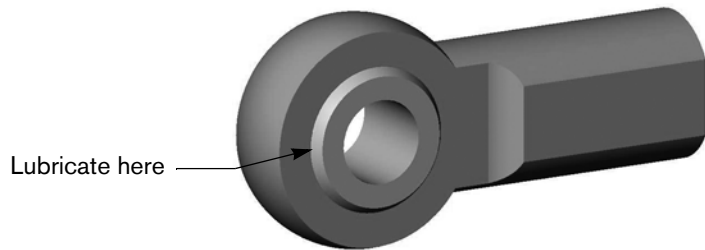

Figure 7: Lubricate cable rod ends with silicone spray lubricant

Important: Do not use petroleum-based lubricants such as WD-40®, Vaseline®, or motor oil.

Clean and Lubricate Guide Rods

Inspect the exposed areas of the guide rods for cleanliness. Using a dry cloth, wipe any buildup of dirt or grease from the rods.

Lubricate the exposed areas of the guide rods by applying a light coat of a silicone spray lubricant. Spray the silicone lubricant on a cloth and then wipe the guide rods with the cloth. *Be careful with any lubricant spray; it can stain carpet and clothing.*

CAUTION: Do not attempt to lubricate the guide rods when the equipment is in use. Attempting to lubricate between the weight plates without completely disassembling the stack will result in serious injury.

Important: Do not use petroleum-based lubricants or motor oil. These lubricants tend to cause a rapid buildup of dirt and hair on the weight plates, which can cause the plates to stick together.

Note: The CW802 Smith Machine has counter-balance guide rods behind the maintenance shields, which should be cleaned and lubricated weekly.

Inspect Cables, Connections, and Tension

Each week, give the cables and connections a thorough inspection and check cable tensions. The following lists the specific things you need to inspect:

- Check the cable termination at the weight stack. Make sure that the cable bolt is threaded at least a minimum of seven turns into the selector stem or a minimum of 1/2-inch (13 mm), so that there is no more than 3/4-inches (19 mm) between the top of the jam nut and base of the bolt head. Check and adjust accordingly. *Also make sure that the locking jam nut is tight against the selector stem.*
- Check the cable, especially near all pulleys, wheels, and cams.
- Check the cable as it terminates at the cam, which is stationary on most equipment. Inspect the bolt passing through the cam end fitting to be sure the two jam nuts are tightened against each other. Also, check the entire cable routing to verify that there is no interference with any structure.
- Inspect the ball end of the cable where the cable connection rests in the clevis housing.
- Ensure that each cable is properly adjusted and tightened at the top of the weight stack.
- Check cable pulleys, end connections, and end fittings. Make sure all connections are tight, adjusting cable tension as necessary.

Inspect Cable Handle Attachments

Check the cable-to-handle attachment area very closely. Refer to Figure 8. Look for frayed cable ends, broken thimbles, bent cables, worn spring clips, worn handles, and any other unusual wear.

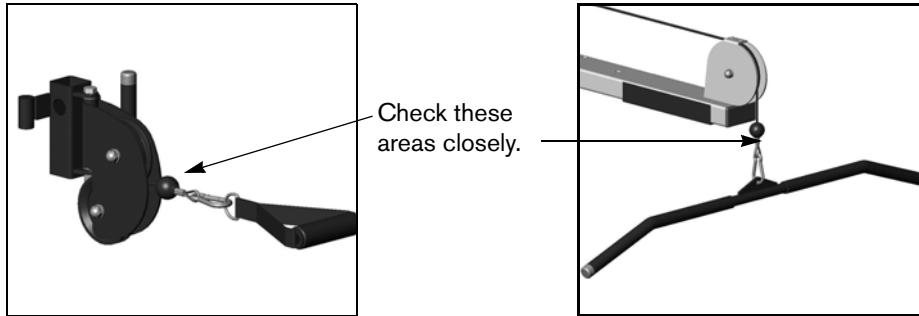

Figure 8: Check connections to handles carefully

Also, check the spring clip gate and make sure it closes properly and engages securely. Refer to Figure 9. Check the spring clip, links, and cable to ensure integrity; replace any spring clip link that does not function properly or shows wear.

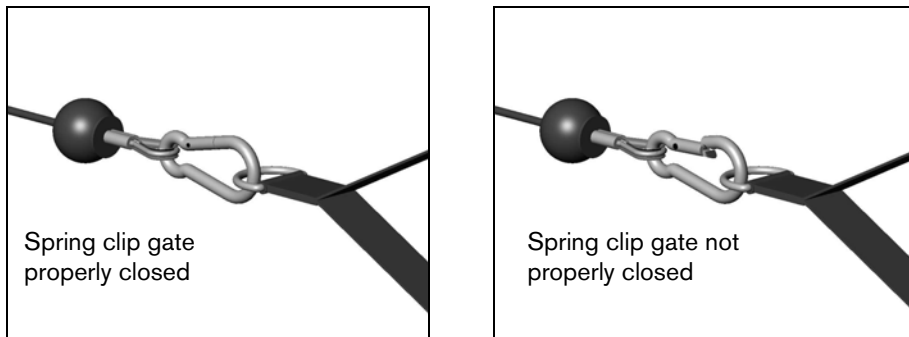

Figure 9: Check spring clip gate to ensure proper closure

Inspect Pulleys

Precor uses precision ball bearing idler pulleys to smoothly guide the cable.

Inspect each pulley for damage, including hairline cracks, chips, or missing sections. Worn surfaces in the pulleys can cause severe damage to the cables and must be replaced at the first sign of wear or damage.

Be certain that the wheels turn freely as the equipment is used. Inspect each pulley for excessive side-to-side play, which indicates worn bearings or loose mounting bolts. If excessive play is discovered, remove the pulley to inspect the bearings, and replace the entire pulley if necessary.

Inspect Weight Stack and Selector Pin

Weight stacks are made of precision machine plates that are designed as a single mechanism to stack precisely. Use only Precor-supplied add-on weights and weight selector pins.

On a weekly basis, inspect weight stacks and selector pins. Wipe each plate with a damp cloth as needed. Inspect all plates for sharp burrs or damage. Wipe dirt and dust off the guide rods.

Make sure the equipment uses only the original Precor selector pin. In addition, make sure the selector pin can be fully inserted and retained in each weight plate.

Inspect and Lubricate Bearings and Bushings

Precor uses high quality bearings designed for strength applications and long service life. Each week, do the following to maintain the bearings and bushings on the equipment:

- **Bronze bushings:** Precor recommends using a small amount of silicone spray lubricant to lubricate the bushings. Spray directly onto the guide rod and then rotate the guide rod through its complete range of motion several times. Inspect bushings for excessive wear and damage. *Be careful when using the spray lubricant; it can stain carpet and clothing.* Wipe off any excess lubricant with a cloth.
- **Nylon bushings:** Lubricate the nylon bushings on the guide rods by applying a light coat of silicone spray lubricant. Spray the silicone lubricant on a cloth, then wipe the cloth along the full length of the guide rod.
- **Sealed Bearing Pivot Points:** These locations are protected from the outside environment and require no lubrication. While cleaning the equipment, wipe down the guide rods and external bearing surfaces with a cloth to prevent the build up of dust and perspiration.

- **Linear Bearings:** Case hardened guide rods are used in areas that use linear bearings (refer to Figure 10). Inspect each end of the rod to ensure they are fastened correctly and all bolts are tight.

Wipe down rods using a light application of a silicon spray lubricant to remove dust, hair, and dirt. Polish the guide rod using fine grade steel wool if surface rust or oxidation is present.

Important: *Do not use petroleum-based lubricants or motor oil. These lubricants tend to cause a rapid buildup of dirt and hair on the weight plates, which can cause the plates to stick together.*

If you lubricate the rods regularly, then the bearings will function as designed. Otherwise, the rods may corrode, which can cause the bearing to become clogged and jammed, leading to the bearing actually gouging the rod. Be sure to remove surface rust and oxidation from the hardened rails immediately.

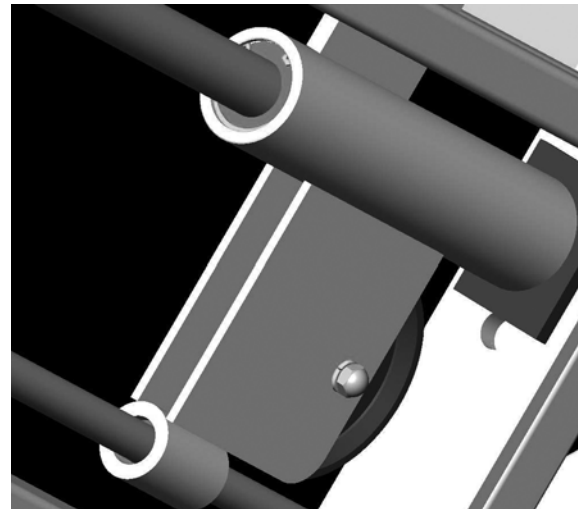

Figure 10: Shows a typical location of a linear bearing in its housing

Check Seat Adjustment and Test Pop Pins

Precor strength equipment has two types of adjustments:

- 2x4-inch or 2x2-inch telescoping sleeve adjustment for most seat assemblies
- 1/2-inch slotted plate adjustments used on most free-weight bench adjustments

Inspect all adjustments for proper fit and function. Inspect plastic sliders for excessive wear or damage.

Adjustments use either a high-tensile pop pin plunger assembly or a ratcheting lever assembly. Inspect and tighten all pop pin caps.

Monthly Inspection

This section covers the tasks you should perform each month to maintain the equipment. Perform the following tasks as appropriate for the unit you are maintaining:

- Inspect frames and movement arms.
- Lubricate pop pins.
- Check and lubricate ratcheting seat lever
- Inspect all fasteners.

Inspect Frames and Movement Arms

Inspect frames and movement arms monthly for proper function and integrity. Check for cracks, chipped paint, or rust. Touch up dings and chips in the paint as needed. Replace any component at first signs of wear.

Note: You can order touch-up paint from Precor by calling Customer Support. Refer to *Obtaining Service*.

Inspect frames for cracks particularly at the joints. If any cracks are found, immediately take the equipment out of service, and repair it using a qualified maintenance technician. Refer to *Important Safety Guidelines for Owners* and *Obtaining Service*.

To remove surface rust from the frame, rub lightly with a fine wet/dry sand paper or fine steel wool. Finish with Precor's touch-up paint if needed. Maintain paint luster with an application of a mild automotive wax product.

To maintain the powder coated and chrome parts, use a mild detergent-based cleaner for light dirt and grime removal. For removing heavier dirt and grease and for polishing, use a good automotive polish. For scuffs and marks that are not removed by the above methods, use a fine-grit cleanser. Do not use solvents, lacquer thinner, acetone, or finger nail polish remover. For high wear areas, ABS shields have been provided. Replacement shields are available from Precor Customer Support. For additional information refer to *Obtaining Service*.

Lubricate Pop Pins

Pull out the pop pin as far as it goes and apply a small amount of silicone spray lubricant. Wipe off any excess lubricant with a cloth. (Refer to Figure 11.)

CAUTION: Pulling out the pop pin may cause the unit to adjust position suddenly. To avoid injury, keep your hands and head away from moving parts.

Test the pop pin for proper function and engagement in each adjustment hole.

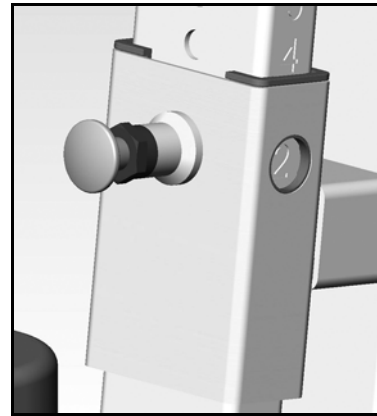

Figure 11: Lubricate the pop pin by pulling it out

Check and Lubricate Ratcheting Seat Lever

Precor designed the ratcheting seat so users can easily move the seat to a comfortable position. After lowering the seat by pressing on the lever to disengage, a user can sit on the seat and pull it up to the desired position. As the seat moves, the ratcheting lever snaps in and out of each hole, making an audible noise.

The ratcheting seat requires little maintenance. However, because seat safety is important to the safety of a workout, you should check the ratcheting seat lever each month to see if it sticks when used. You also want to ensure that the pin fully engages in each adjustment hole.

To test if the seat lever needs lubrication, slightly elevate the seat while pressing and releasing the lever. The lever should snap back out easily. If the lever sticks, lubricate the pivot pin in the lever with silicone spray lubricant. Wipe off any excess lubricant with a cloth. (Refer to Figure 12.)

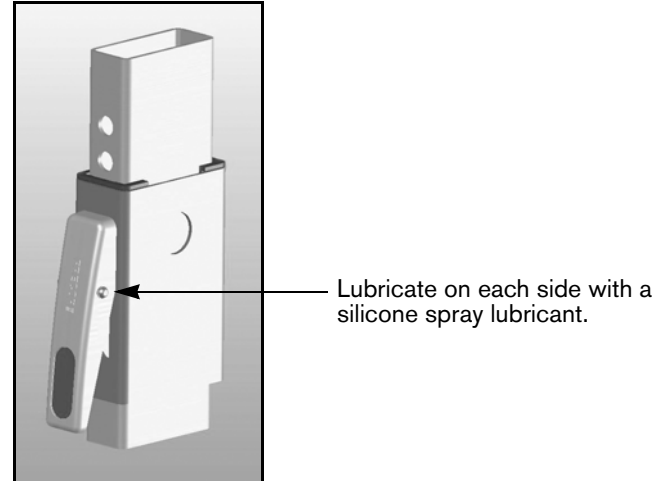

Figure 12: If needed, lubricate the pivot pin on the ratcheting seat lever

If desired, you can detach the seat by removing the retaining pin, allowing you to remove the chrome for cleaning. Removing the seat also allows clear access to the ratcheting lever to test its pivoting action.

Inspect All Fasteners

Precor products are assembled with Grade 5 fasteners or better. With normal use, these fasteners can loosen. Inspect all nuts, bolts, hex key bolts, screws, and other fasteners to ensure they are tight and installed correctly.

Be sure to check fasteners at bolted joints to ensure connection is secure. If the fastener is loose, but in good condition, retighten it. If you are concerned about the integrity of the fastener, remove it, clean the threads, and inspect it for any damage such as cracks, bad threads, corrosion, or rust. Reinstall the fastener if it appears to be in good condition. Otherwise, remove the equipment from service until a new fastener can be installed properly. You can order new fasteners from Customer Support. Refer to *Obtaining Service*.

Annual Maintenance

Perform these tasks on an annual basis, as appropriate for your equipment:

Weight Stack Annual Maintenance

Once a year, Precor recommends disassembling the weight stack to clean and inspect it thoroughly.

- Carefully remove the cable and guide rods from the weight stack. Completely disassemble the weight stack in a well-ventilated area, away from the exercise floor.
- Inspect weight plates and clean them thoroughly. Cracked or broken plates should be replaced immediately (refer to *Obtaining Service* to purchase replacements). Clean each plate individually and inspect guide bushings.

- Inspect the bushings of the top weight plate and each individual weight plate and replace a plate if it is excessively worn or broken.
- Clean the selector stem and inspect it for wear and damage.
- Reassemble the weight stack.
- Wipe down the weight stack enclosures (shrouds) with a damp cloth as needed. Inspect all fasteners to ensure the shroud is securely mounted.

Important: Precor recommends that you replace worn and damaged cables during routine maintenance. It is recommended that all cables be replaced annually.

Inspect and Lubricate Pop Pins

Remove the pop pin assembly by loosening the hex head cap.

CAUTION: Pulling out the pop pin may cause the unit to adjust position suddenly. To avoid injury, keep your hands and head away from moving parts.

Inspect the plunger and spring for excessive wear and damage, and replace as required.

Apply a small amount of silicone spray lubricant to the spring and plunger, and then reinstall the entire assembly. Tighten hex head cap. Wipe off any excess lubricant with a cloth.

Pop pin plunger assembly shown with telescoping sleeve type adjustment

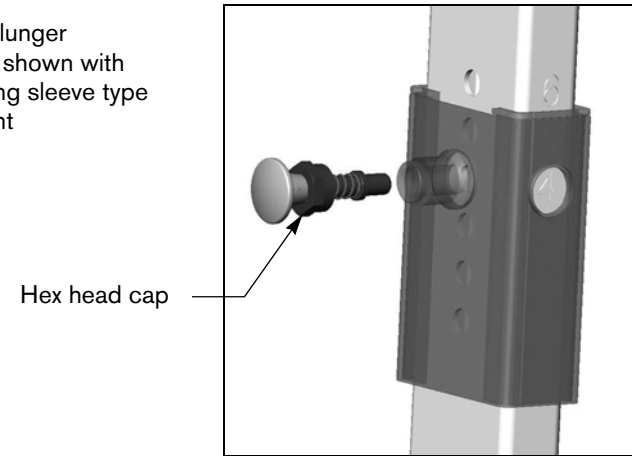

Figure 13: Inspect pop pins (pop pin shown in exploded view for clarity)

Recommended Maintenance Checklist

Please retain for your records.



Maintenance Record the Month of _____
 Brand Name _____
 Model Name & Number _____
 Serial Number _____
 In Service Date _____

Initial box when completed: write N/A if not applicable to the equipment.

	1	2	3	4	5	6	7	8	9	10	11	12	13	14	15	16	17	18	19	20	21	22	23	24	25	26	27	28	29	30	31	
Daily Check																																
Clean upholstery																																
Clean & inspect frames																																
Inspect pads for wear																																
Inspect cables & end connections																																
Check labels and placards																																

	7						14						21						28												
Weekly Check																															
Condition & clean upholstery																															
Clean & lubricate cable rod ends																															
Clean & lubricate guide rods																															
Inspect cables/connections/tension																															
Inspect cable handle attachments																															
Inspect pulleys																															
Inspect each weight stack & Pin																															
Inspect & lube bearings & bushings																															
Check seat adjust. and pop pins or ratcheting lever																															

	28																													
Monthly Check																														
Inspect frames & movement arms																														
Inspect & lubricate pop pins or ratcheting lever																														
Check & lubricate ratcheting seat																														
Inspect all fasteners																														

Annual Check		
Weight stack maintenance	Date:	Initials:
Inspect & lubricate pop pins or ratcheting lever	Date	Initials:

Maintenance Tips

- Upholstery Wipe clean using a mild soap and water solution or other appropriate cleaner for vinyl.
- Cable Replace any cable that shows signs of wear or damage.
- Frames Wipe clean using a mild soap and water solution.
- Guide rods Lubricate guide rods with silicone spray lubricant.

Important: It is recommended that cables be changed annually. Only factory provided selector key, lanyard, handle attachment, and handle should be used on selectorized weight stacks. Use of any parts other than those provided by the manufacturer will invalidate the product warranty and may cause injury to users.

Notes:



Precor Incorporated
20031 142nd Ave NE
P.O. Box 7202
Woodinville, WA USA 98072-4002

Precor, Icarian, Jade, and Move Beyond are registered trademarks of Precor Incorporated.

Super Lube is a registered trademark of Synco Chemical Corporation.

WD-40 is a registered trademark of CD-40 Company.

Vaseline is a registered trademark of Unilever.

Copyright 2014 Precor Incorporated.

Specifications subject to change without notice.

www.precor.com

NOTICE:

Precor is widely recognized for its innovative, award winning designs of exercise equipment. Precor aggressively seeks U.S. and foreign patents for both the mechanical construction and the visual aspects of its product design. Any party contemplating the use of Precor product designs is hereby forewarned that Precor considers the unauthorized appropriation of its proprietary rights to be a very serious matter. Precor will vigorously pursue all unauthorized appropriation of its proprietary rights.