

**PRECOR<sup>®</sup>** USA

**903**

**904**

Electronic  
Console

Owner's Manual  
Assembly and Operation

## Safety Information

Please review and observe the following safety guidelines when assembling and using the Precor 903/904 electronic console:

*Before beginning any fitness program, you should see your physician for a thorough physical examination.*

- Read the Owner's Manual and follow all instructions. These instructions are written to ensure your safety and to protect the equipment.
- Handle the Precor 903/904 electronic console with care. Do not drop the equipment. It might damage the device and you could void the Precor limited warranty.
- After extensive use, the batteries may wear out which causes the information on the display to flicker erratically or not appear at all. If you need to replace the batteries, refer to *Replacing the Batteries* in the maintenance section of this manual.
- Do not operate the treadmill for a 24-hour period after installing the magnet and reed switch. A 24-hour period is required so that the adhesive on the mounting pads can bond properly.

The Precor 903/904 electronic console is designed to enhance your workout. By following the above precautions and using good common sense, you will have many safe and enjoyable hours of healthy exercise with your Precor products.

## Obtaining Service

Do not attempt to service the 903/904 electronic console yourself other than assembling the magnet and reed switch and maintaining the electronic console as discussed in this manual.

For information about product operation or service, contact an authorized Precor dealer (or a Precor Factory Authorized Service Company). To locate the Precor dealer or service company nearest you, call 1-800-4-PRECOR.

## Table of Contents

<b>Safety Information</b> .....	2
Obtaining Service .....	2
<b>Before You Begin</b> .....	4
Unpacking the Electronic Console .....	4
<b>Installing the Electronic Console</b> .....	5
903 Assembly Procedures .....	5
904 Assembly Procedures .....	9
<b>Installing the Mounting Pads</b> .....	12
<b>Attaching the Magnet and Reed Switch</b> .....	14
<b>Using the Electronic Console</b> .....	17
Electronic Console Buttons .....	17
Electronic Console Displays .....	18
Setting the Timer .....	19
Setting the Distance .....	19
Resetting Your Workout Statistics .....	19
<b>Maintaining the Electronic Console</b> .....	20
Replacing the Batteries .....	20
<b>Appendix A — Flywheel Template</b> .....	23

## Before You Begin

Thank you for purchasing the easy-to-use electronic console option for your Precor 903 Manual or 904 Total Body Treadmill. Before assembling the console onto your treadmill, take the time to read through this manual so that you are familiar with the contents of the package and the features on the electronic console.

Obtain the appropriate tools before assembling the electronic console onto the 903 or 904 treadmill. You will need a Phillips head screwdriver to attach the electronic console onto the handrail clamp.

## Unpacking the Electronic Console

Carefully unpack the electronic console and its components. Make sure that you have the following items:

- one electronic console
- one mounting bracket with four (two short and two long) Phillips head screws
- one reed switch and wire
- one magnet
- three C clips—holds reed switch wire to handrail
- two mounting pads (one thick and one thin pad)

If any items are missing, contact the dealer from whom you purchased the treadmill or call 1-800-4-PRECOR for the dealer nearest you.

## Installing the Electronic Console

The handrail clamp can be used on either the 903 or 904 treadmill. However, the steps used to install the console onto the clamp are slightly different depending on which treadmill you have. Please refer to the steps that apply to your treadmill.

### 903 Assembly Procedures

To install the 903 electronic console, take the following steps:

1. Locate the handrail clamp in the box that accompanies the electronic console's box. Remove the long and short screws from the handrail clamp using your fingers or a Phillips head screwdriver. Set the screws aside. You can discard the short screws since they are only used for the 904 assembly.

*Diagram 1*

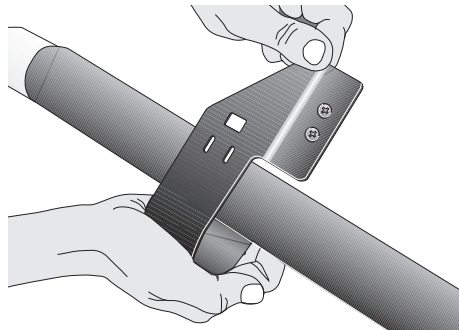

2. Place the handrail clamp around the mid-portion of the handrail as shown in Diagram 1. Place a hand on either side of the handrail clamp to gently pull it apart so that you can slide it onto the handrail's foam grip.

**Important:** Do not mount the clamp on the painted surface of the handrails.

*Diagram 2*

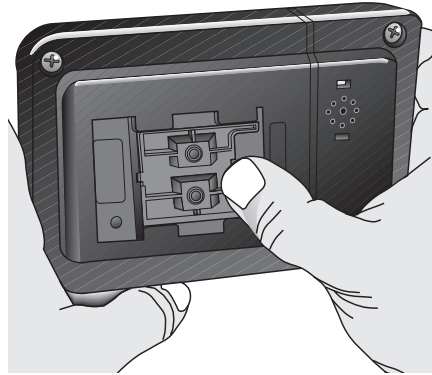

3. Unlock and remove the mounting bracket from the back of the electronic console. Unlock the mounting bracket by pushing it down toward the base of the console. See Diagram 2.

*Diagram 3*

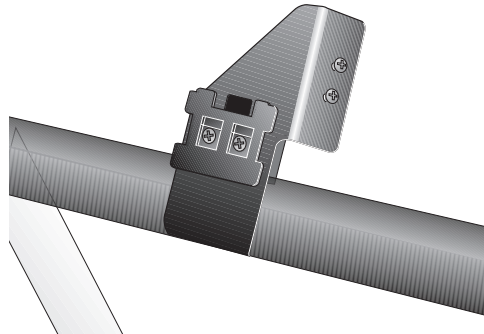

4. Position the mounting bracket onto the handrail clamp so that the smooth side of the plate is facing you. See Diagram 3.

5. Secure the mounting bracket and clamp by inserting the two long screws through the mounting holes. You may need to squeeze the ends of the clamp together to install the screws. See Diagram 3. Tighten the screws into the recessed holes on the mounting plate using the Phillips head screwdriver. Do not over tighten the screws. A gap should remain between the opposite sides of the handrail clamp.

*Diagram 4*

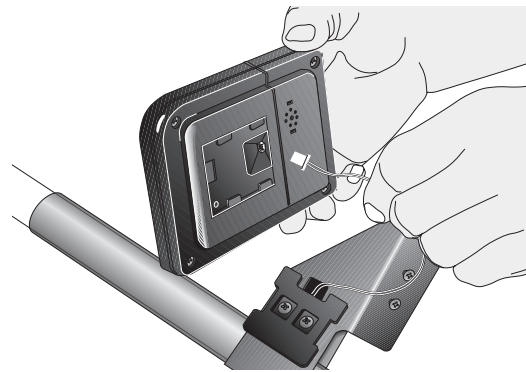

6. Unwrap the reed switch wire. Route the connector and wire through the hole in the handrail clamp. See Diagram 4.
7. Plug the connector into the receptacle as shown in Diagram 4. Do not force the connection. The connector is designed to engage in one direction only. A tab on the connector and a slot on the receptacle help you determine the proper alignment.
8. Align the back of the console with the mounting bracket and slide the electronic console onto it. Gently pull the excess wire through the hole in the handrail clamp while you slide the console toward the rear of the treadmill.

*Diagram 5*



9. Attach the C clips around the handrail as shown in Diagram 5. Position the slight protrusion on the C clip around the reed switch wire and micro-adjustment knob cable. Squeeze the C clips together to close them and secure the wires in place.
10. With the electronic console successfully mounted, continue to *Installing the Mounting Pads*.



### 904 Assembly Procedures

To install the 904 electronic console, take the following steps:

1. Remove the handrail clamp from its box. Take the long and short screws out of the handrail clamp using your fingers or a Phillips head screwdriver. Set the screws aside.

*Diagram 6*

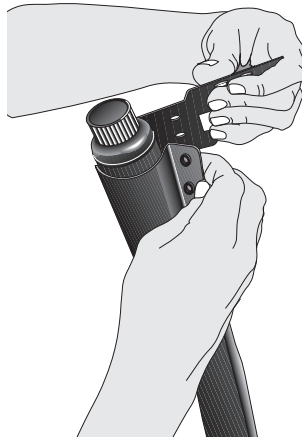

2. Position the handrail clamp over the right handrail's micro-adjustment knob as shown in Diagram 6. Place a hand on either side of the handrail clamp to gently pull it apart so that you can slide it onto the handrail's foam grip and into position (about 8 inches above the base of the foam grip).

**Important:** Do not mount the clamp on the painted surface of the handrails.

*Diagram 7*

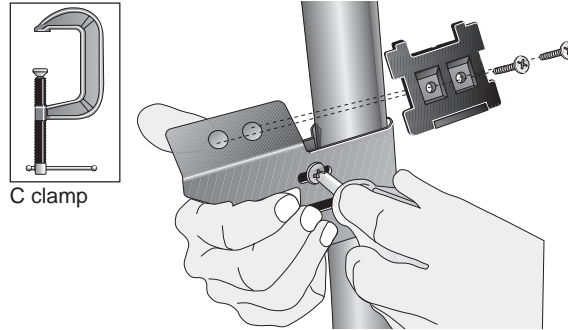

3. Insert the long screws through the mounting holes on the clamp. See Diagram 7. You may need to squeeze the ends of the clamp closer together to install the screws. Tighten the screws using a Phillips head screwdriver until the clamp remains securely in place. A gap should remain between the opposite sides of the clamp. See Diagram 7.

**Note:** If you have difficulty holding the clamp together, you may want to use a C clamp (see insert on Diagram 7) to help compress the clamp ends while you tighten the screws.

4. Unlock and remove the mounting bracket from the back of the electronic console. (Unlock the mounting bracket by pushing it down toward the base of the console.) Refer to Diagram 2 on page 6.
5. Position the mounting bracket onto the handrail clamp so that the smooth side of the plate is facing you. Refer to Diagram 7. Secure the mounting bracket by inserting the two short screws. Tighten the screws into the recessed holes on the mounting plate using the Phillips head screwdriver. Do not over tighten the screws because too much pressure may crack the plastic mounting plate.
6. Unwrap the reed switch wire. The reed switch wire has a connector on one end and the oblong-shaped reed switch on the opposite end. Refer to Diagram 5 on page 8.

*Diagram 8*



7. Position the electronic console over the handrail clamp and plug the connector into the receptacle. See Diagram 8. Do not force the connection. The connector is designed to engage in one direction only. A tab on the connector and a slot on the receptacle help you determine the proper alignment.
8. Slide the electronic console onto the mounting bracket. It should "click" into place as you slide it toward the rear of the treadmill.
9. Attach the C clips around the handrail as shown in Diagram 5 on page 8. Position the slight protrusion on the C clip around the reed switch wire and micro-adjustment knob cable. Squeeze the C clips together to close them and secure the wires in place.
10. With the electronic console successfully assembled, continue to *Installing the Mounting Pads*.

## Installing the Mounting Pads

Two adhesive-backed foam pads (one thick and one thin pad) accompany your electronics option package. The thick pad is used as a spacer and you place the reed switch on it. The thin pad is positioned onto the flywheel and becomes the base for the magnet.

**CAUTION:** Both pads require a 24-hour period to bond properly to the equipment. Do not operate the treadmill during this time.

Diagram 9

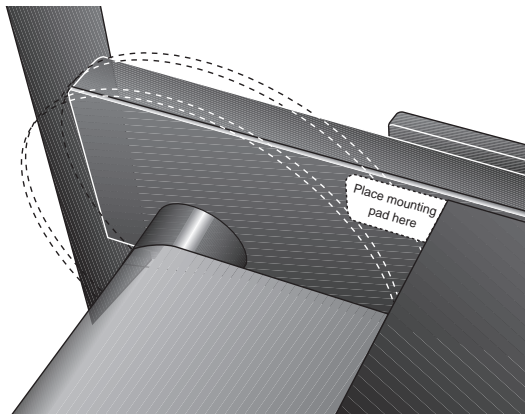

To install the mounting pads to the flywheel and side rail on your 903 or 904 treadmill, take the following steps:

1. Locate the area on the side rail between the right roller guard and the deck of the treadmill. See Diagram 9.

**Note:** Right and left are determined by standing behind the rear roller and facing the handrail(s).

*Diagram 10*

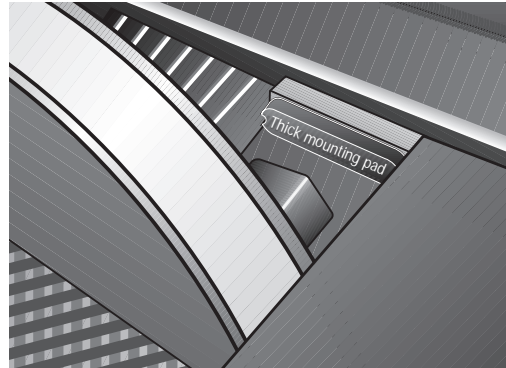

2. Remove the paper backing from one side of the thick pad and press the pad firmly in place between the roller guard and the deck of the treadmill. See Diagram 10.
3. Make a *copy* of the template shown in Diagram A. See Appendix A. Cut along the dotted lines. Carefully cut away the shaft section and the magnet mounting pad island.
4. Lay the template against the right flywheel. Use a pencil to mark the outline for the magnet mounting pad. Remove the template.

**Diagram 11**

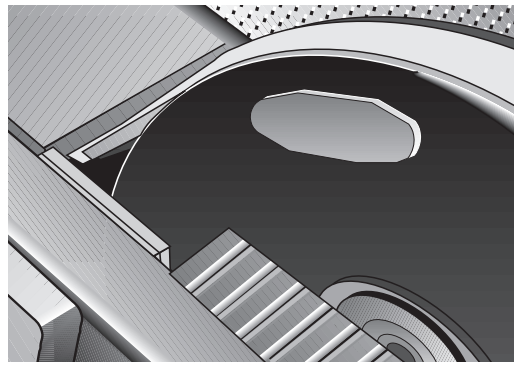

5. Remove the paper backing from one side of the thin pad and press the pad firmly in place onto the flywheel. See Diagram 11.
6. To mount the magnet and reed switch continue with the steps below, *Attaching the Magnet and Reed Switch*.

### **Attaching the Magnet and Reed Switch**

For the electronic console displays to operate properly, a magnet and reed switch need to be precisely installed. The magnet is mounted to the flywheel and the reed switch is placed on the side rail. Mounting pads indicate where you need to mount the hardware. Be sure to follow the previous instructions *Installing the Mounting Pads* before attaching the magnet or reed switch.

**To install the magnet and reed switch, take the following steps:**

***CAUTION:*** *To ensure the integrity of the reed switch, lower the handrails before mounting the reed switch. Allowing excess wire near the flywheel eliminates the possibility that the reed switch will be pulled out of position. If you are not sure how to lower the handrails, refer to your Owner's Manual.*

Diagram 12

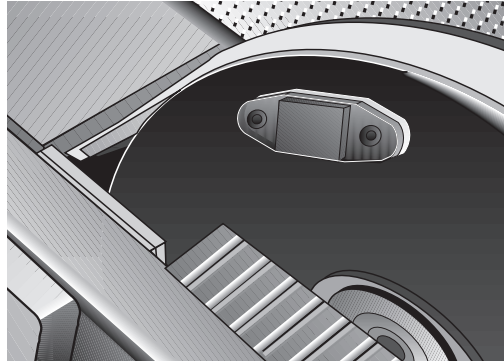

1. Remove the paper from the adhesive strip on the flywheel's foam mounting pad.
2. Wipe the back of the magnet with a dry clean, soft cloth. Position it over the foam mounting pad on the flywheel and press it onto the adhesive strip. Check that it is securely mounted. See Diagram 12.
3. Wipe the base of the reed switch (the "base" is the side opposite the ++) with a clean cloth.

**CAUTION:** Check the alignment of the +'s on the reed switch with the magnet before adhering the reed switch onto the side rail mount. For the electronics to operate properly, the magnet can only pass over one of the +'s on the reed switch.

4. To check the alignment between the magnet and reed switch, move the flywheel slightly so that you can place the base of the reed switch onto the foam mounting pad. You should be able to see and read the positive (+) signs. Position the reed switch between the roller guard and deck so that the magnet passes over one of the "+" markings on the reed switch.

**Important:** If the magnet passes over both "++" on the reed switch, a false count or an erratic display can appear on the electronic console.

*Diagram 13*

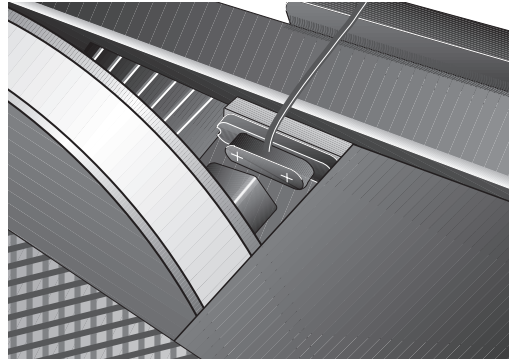

5. Remove the paper to expose the adhesive strip that is on the foam mounting pad. Press the reed switch onto the pad. Be sure that the reed switch is positioned so that the wires are easily routed up the handrail. See Diagram 13.
6. Rotate the flywheel by hand to make sure that the magnet and reed switch are secure and are not rubbing on each other or on the treadmill. Check that the reed switch wire is clear of the flywheel. If the magnet and flywheel are not correctly aligned you may get incorrect readings on the display. Reposition the magnet and reed switch if necessary.
7. Secure the handrails into an upright position.
8. Check the wires to be sure no excessive amount of wire hangs down where it could cause entrapment or injury to someone. Realign the wire and move the C clips along the handrail if necessary.
9. **DO NOT OPERATE** the treadmill for a 24-hour period. The adhesive on the mounting pads requires this amount of time to bond properly.



## Using the Electronic Console

The electronic console provides multiple features and an easy-to-read LCD display that lets you review your progress as you work out. The three buttons on the console let you control what information you want to display.

The features, TIME, SPEED, DISTance, and CALORies, appear sequentially while in SCAN mode or you can “select” and display one particular feature. See Diagram 14 below. To use and enjoy the electronic console to the fullest extent, please take time to review the following information.

*Diagram 14*



## Electronic Console Buttons

**SELECT**— turns the console ON. The electronic console automatically starts up in SCAN mode which sequentially displays each feature (TIME, SPEED, DISTance, and CALORies) as you work out. While in the SCAN mode, the feature's icon appears and blinks on the display. Applying constant pressure to the SELECT button causes the display to SCAN faster.

To hold on one particular feature, press the SELECT button while the feature (such as TIME) is being displayed. The icon stops blinking. To return to SCAN mode, press the SELECT button one more time.

The electronic console automatically shuts off when the treadmill is not in use after approximately 4 minutes.

**CLEAR**— resets the displays back to zero. You can also use the CLEAR button in conjunction with the SET button to predetermine the time or distance of your workout. See *Setting the Time* or *Setting the Distance*.

**SET**— is used in conjunction with the SELECT and CLEAR buttons to predetermine the time or distance of your workout.

## Electronic Console Displays



**TIME**—shows how long you have been working out in minutes and seconds. To set the duration of your workout, refer to *Setting the Timer*.



**SPEED**— displays your current workout pace by calculating and averaging your approximate miles per hour.



**DISTANCE**— continuously counts the total number of miles accumulated during your workout. It can record up to 99 miles before starting over at zero.



**CALORIES**— shows the estimated total number of calories burned during your workout.

### **Setting the Timer**

The timer lets you set the duration of your workout. When the selected amount of time is up, an alarm beeps for about 10 seconds. To set the timer, take the following steps:

1. When TIME is displayed, press the SELECT button. The icon stops blinking and the TIME display continues to count the minutes and seconds.
2. Press the CLEAR button to reset the display to zero.
3. Press the SET button to choose the amount of time you want to work out. The TIME display advances in 1 minute increments. You can select up to 99 minutes before the display returns to zero.
4. Press the SELECT button to start the countdown.

### **Setting the DISTANCE**

If you have a specific number of miles that you want to travel during your workout, use this feature. An alarm sounds when you reach the specified distance. To set the distance, take the following steps:

1. When DISTANCE is displayed, press the SELECT button. The icon stops blinking.
2. Press the CLEAR button to reset the display to zero.
3. Press the SET button to choose the distance that you want to travel. You can set distance in 0.5 mile increments and select up to 99.5 miles.
4. Press the SELECT button to start the countdown.

### **Resetting Your Workout Statistics**

You can clear the displays and reset your workout statistics to zero by pressing all three buttons (SELECT, CLEAR, and SET) at the same time. All the features on the display appear and then TIME displays and the count up continues.

## Maintaining the Electronic Console

Use a damp, clean cloth after every workout to wipe off any perspiration that might have fallen on the electronic console. Periodically, clean the electronic console using a cloth dampened with a mild dishwashing detergent solution. Rinse the solution off with a clean, damp cloth. Thoroughly dry the electronic console before using it.

***CAUTION: Do not immerse the electronic console in liquid.***

### Replacing the Batteries

Your electronic console comes equipped with fresh batteries already installed. Over time the batteries can wear out and will need to be replaced. Signs that the batteries are low include:

- fading LCD display
- erratic display function
- failure to turn ON when the SELECT button is pressed
- no display when the running belt is moving

**To replace the two (A-76 type) batteries, take the following steps:**

1. Carefully remove the electronic console from the handrail's mounting bracket by sliding it forward.

*Diagram 15*

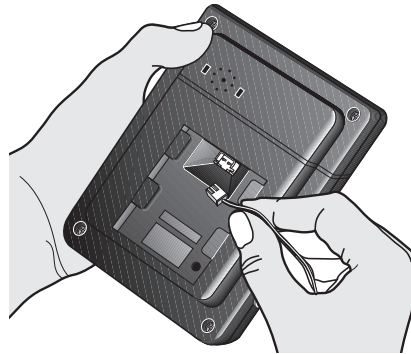

2. Disconnect the reed switch wire by gently pulling the connector out of the receptacle. See Diagram 15.

*Diagram 16*

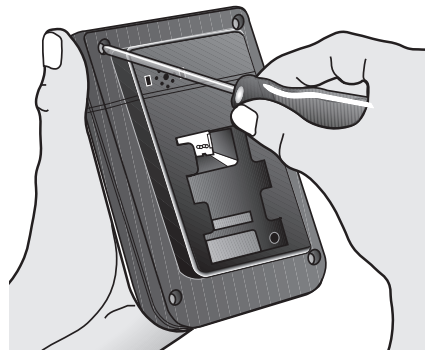

3. Remove the back of the electronic console by unscrewing the four Phillips head screws. See Diagram 16. Set the screws aside.
4. Use your finger to pull up on the battery holder and slide the battery out. You may want to use your screwdriver to help push the old battery out of its holder. Discard the batteries.

*Diagram 17*

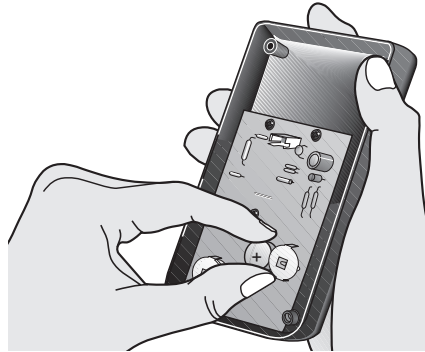

5. Reinsert two fresh batteries. Remove the existing batteries from the unit and reinsert two fresh (A-76 type) alkaline batteries. The positive (+) side should be facing you. See Diagram 17.

**Note:** All the LCD segments momentarily appear when the fresh batteries are installed.

6. Replace the back of the electronic console by inserting the four Phillips head screws back into place. Tighten the screws using the Phillips head screwdriver.
7. Reconnect the reed switch wire into the console. For the 903 treadmill, be sure to route the wire through the hole on the handrail clamp before reconnecting the wire.
8. Slide the console back onto the mounting bracket.
9. Reset the display by pressing all three buttons (SELECT, CLEAR, and SET) at the same time.
10. Press the SELECT button if you wish to turn the electronic console ON.

# Appendix A

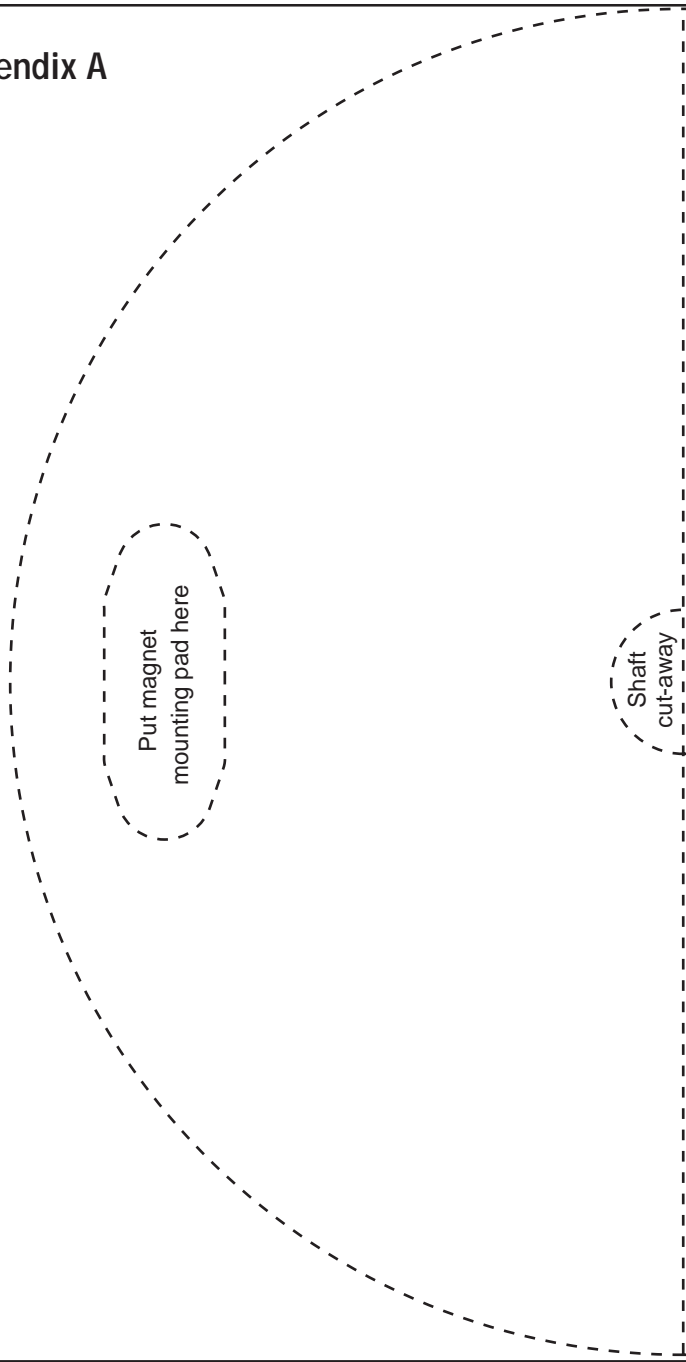

Put magnet mounting pad here

Shaft cut-away

Make a copy of this template or trace the pattern onto a different sheet of paper before cutting along the dotted lines.

**PRECOR**<sup>®</sup> USA

Precor Incorporated  
P.O. Box 3004  
Bothell, WA USA 98041-3004

Precor is a registered trademark of Precor Incorporated.  
© 1996 Precor Incorporated.  
Protected by one or more of the following US and foreign  
patents: US 5,007,630; US D303,414; US D313,826;  
TW 21,389. Specifications subject to change without notice.  
1-800-4-PRECOR

P/N 36687-102  
Web version 9/98

**NOTICE:**

Precor is widely recognized for its innovative, award winning designs of exercise equipment. Precor aggressively seeks U.S. and foreign patents for both the mechanical construction and the visual aspects of its product design. Any party contemplating the use of Precor's product designs is hereby forewarned that Precor considers the unauthorized appropriation of its proprietary rights to be a very serious matter. Precor will vigorously pursue all unauthorized appropriation of its proprietary rights.

 Printed on Recycled Paper